



TBG48 Series Boat Transport Trailer 48'

Specifications

| Model | TBG48-183 | TBG48-213 | TBG48-243 |
|---------------------|---|------------------------|------------------------|
| G.V.W.R. | 18,000 lbs. | 21,000 lbs. | 24,000 lbs. |
| Weight | 4,441 lbs. | 4,903 lbs. | 5,254 lbs |
| Length, overall | 48' | | |
| Width, overall | 102" | | |
| Height, overall | 7' | | |
| Deck length | 40' | | |
| Deck height | 22" | | |
| Deck width | 76" Inside Frame Rails | | |
| Electrical System | D.O.T. and N.H.T.S.A. Approved. Stop, tail, turn and clearance lights, incandescent. D.O.T. tape | | |
| Electrical Plug | 7-way RV standard | | |
| Frame | Steel tube 8"x2" main frame, steel tube 6"x2" crossmembers | | |
| Belly Rail | Steel square tube 2" | | |
| Tie Down Rail | Steel channel 3" x 1-1/2" | | |
| Fenders | Steel galvanized teardrop | | |
| Brakes | Electric drum brakes, all axles standard, with battery backup breakaway kit | | |
| Gooseneck | Steel tube 8"x2" | | |
| Axles | 3 x 6,000 lb Accu-Lube | 3 x 7,000 lb Accu-Lube | 3 x 8,000 lb Accu-Lube |
| Suspension | 2 x 4,000 lb. | 2 x 4,000 lb. | 2 x 4,000 lb. |
| Tires | LT235/85R16 E rated | LT235/85R16 G rated | 215/75R-17.5 H rated |
| Wheels | 16 x 6 OEM 8 lug | 16 x 6 OEM 8 lug | 17.5 x 6.75 OEM 8 lug |
| Spare tires | 2 mounted, 1/side, same as above | | |
| Jack | 2-12,000 lb Drop leg | | |
| Coupler | Gooseneck hitch, Adjustable, 2-5/16" ball | | |
| Safety Chains | 2 x 15,000 lb. 3/8" with hook | | |
| Ramps | N/A | | |
| Finish | Black zinc based transport finish | | |
| Bunk, 2' straight | 4 | | |
| Bunk, 6' straight | 2 | | |
| Bunk, 12" 'V' notch | 3 | | |
| Screw pad | 4 | | |

Broward Trailer

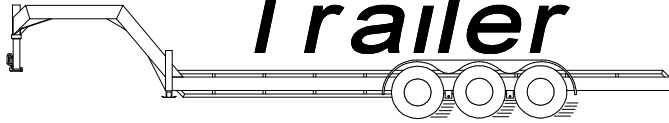

TBG48 Series Boat Transport Trailer 48'

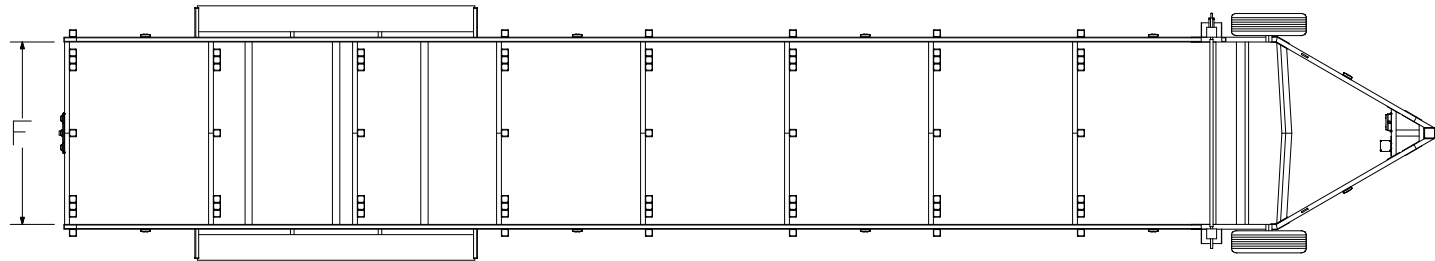

TOP VIEW

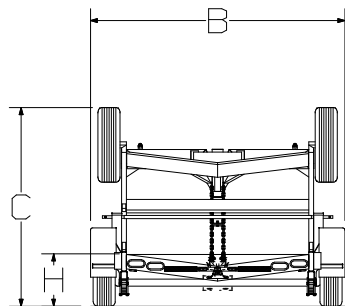

REAR VIEW

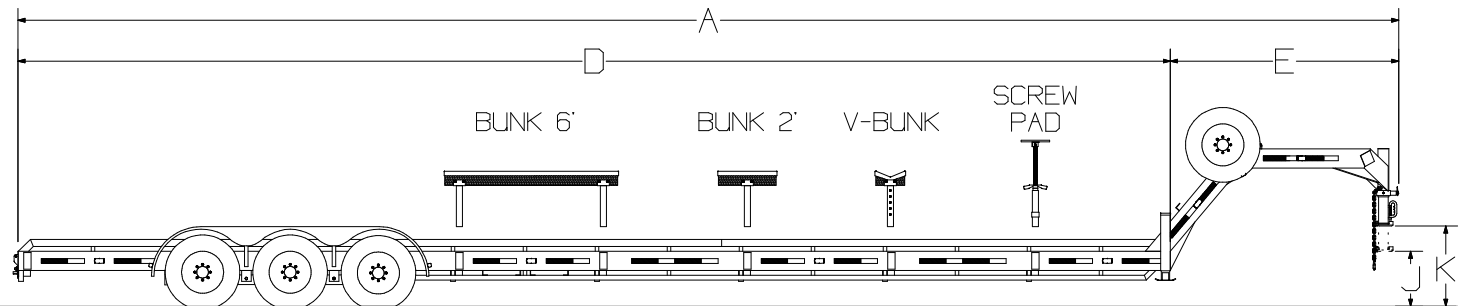

RIGHT SIDE VIEW

| | | |
|---|------|--------------------------------|
| A | 48' | TOTAL LENGTH |
| B | 102" | TOTAL WIDTH |
| C | 7' | TOTAL HEIGHT |
| D | 40' | DECK LENGTH |
| E | 8' | GOOSENECK LENGTH |
| F | 76" | WIDTH BETWEEN MAIN FRAME RAILS |
| H | 22" | DECK HEIGHT |
| J | 23" | MINIMUM COUPLER HEIGHT |
| K | 33" | MAXIMUM COUPLER HEIGHT |